

Log fired heating system



firestar
15 - 40



Expertise is our success...



HERZ-Armaturen Ges.m.b.H

The company

Founded in 1896, Herz has been continuously active in the market for more than 110 years. HERZ Armaturen Ges.m.b.H. has five sites in Austria and three other locations in Europe with more than 1.400 employees. Today, HERZ is the leading Austrian manufacturer playing a significant role in the global heating industry.

Feuerungstechnik (boiler) division

HERZ Feuerungstechnik in Sebersdorf/Styria was founded in 1883. Today more than 120 people work in production and sales. At the company's location in Pinkafeld / Burgenland is a modern manufacturing and a laboratory for new and innovative products available. Over the years HERZ Feuerungstechnik has established itself as a specialist for biomass

heating. The main focus for this is placed upon modern, cost efficient and environmentally friendly heating systems with highest levels of comfort and convenience as well as being userfriendly.



A heart for the environment

All HERZ boiler exceed the strictest emission regulations. This is proven by various environmental seals of approval.

HERZ quality

Herz design engineers are in regular contact with acknowledged research institutions in order to further improve the very high standards.



Decades of experience

- In-house development and testing centre
- Austrian quality and European-wide sales and marketing
- Comprehensive service
- ISO 9001 certification
- FMEA approved boiler production

Innovative technology for the most natural fuel!

Logs & wood briquettes



Convenient heating...



Efficient and convenient heating using wood

Simple, fast and user-friendly firing up without kindling.

The very quiet running of the boiler is due to high quality system components.

The large filling shaft for big logs guarantees a long burning time – of up to 8 hours with a full load (depending on boiler-type).



The greatest advantages of the HERZ firestar:

- Energy-saving combustion due to the unique double vortex combustion chamber
- Automatic cleaning of the heat exchanger - no work required
- Consistently high level of efficiency
- Simple removal of combustion & fly ash from the front – no side cleaning apertures
- Low ash accumulation due to optimum combustion

Control unit as standard for:

- 2 heating circuits
- Domestic hot water
- Buffer management
- Return flow temperature bypass

Benefits and details...



Control using the HERZ BioControl 3000

Central control unit as standard with:

- 2 controlled heating circuits (pump and mixer valve)
- domestic hot water
- Buffer management
- Return flow temperature bypass (pump and mixer valve)
- Simple screen design and convenient menu guidance.
- Modular extension option for solar circuit control as well as other heating circuits (total maximum 6 heating circuits, for solar maximum 5 circuits).



Smoke extraction via open filling shaft door

- To avoid smoke escaping when the filling shaft door is opened the ventilator sucks out the gases via the smoke extraction channel.
- Ensures a smoke free boiler room without interrupting the combustion process



Highly efficient due to the double vortex combustion chamber

- The revolutionary double vortex combustion chamber ensures optimum blending of the combustion gases with oxygen.
- The flame is distributed across 2 chambers and therefore ensures highly efficient combustion.
- The combustion chamber consists of heat-resistant fireproof concrete (SiC) no sheet metal parts ➡ no wear and tear ➡ which means DURABILITY

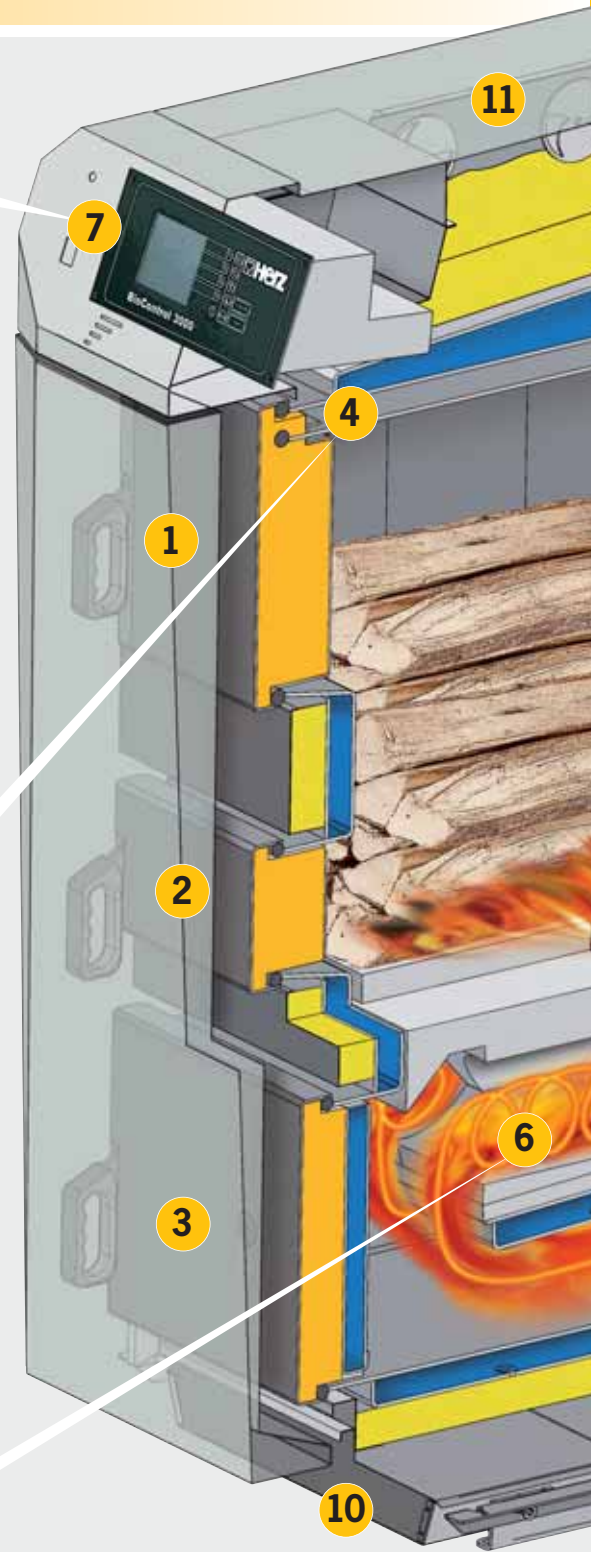

- 1. Filling shaft door**
Simple firing using large 50 cm logs
- 2. Large firing up door**
Fast and simple firing up without kindling due to innovative technology
- 3. Cleaning door**
Simple removal of combustion and fly ash from the front

...of the HERZ firestar 15-40

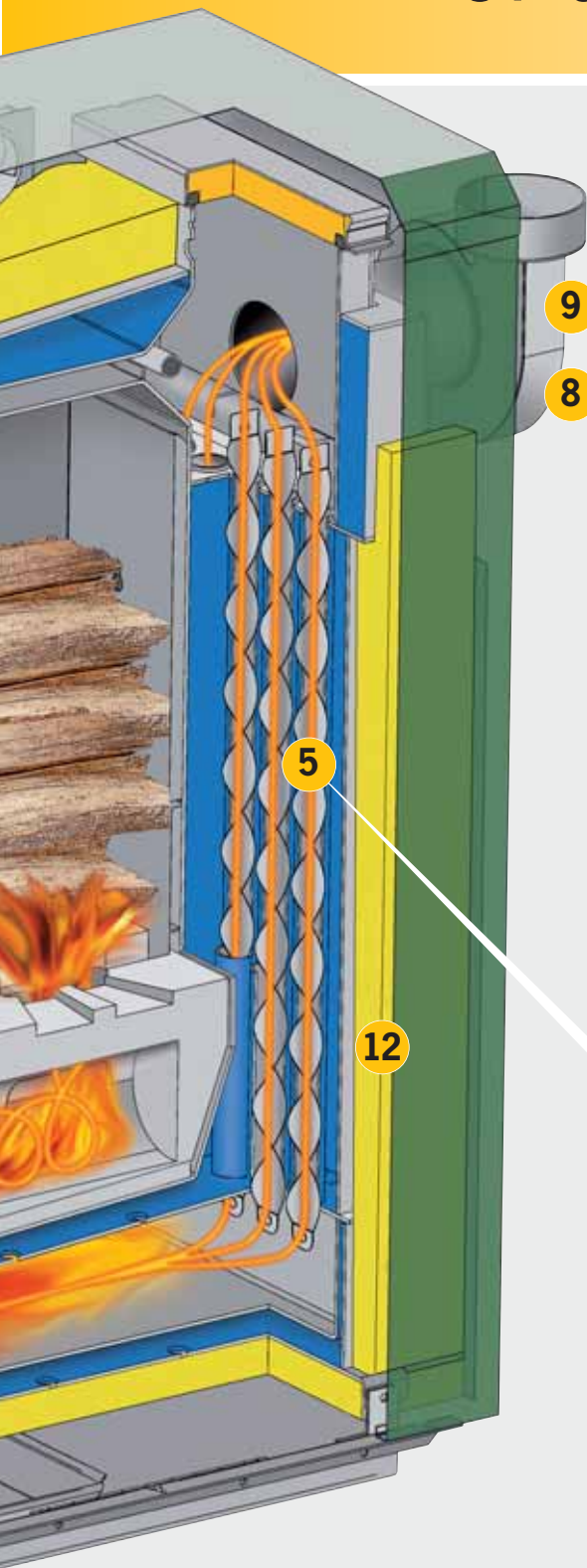

Energy-saving combustion



- With built-in Lambda probe, which constantly monitors the flue gas values, the boiler responds to variations in fuel quality ensuring ideal combustion efficiency and the lowest emissions.
- The Lambda probe controls the primary and secondary air input, always achieving the cleanest combustion, even in partial load operation.
- Sophisticated controls optimise flue gas temperature to maintain boiler performance.
- The results are lower fuel consumption and the lowest emission values even with varying fuel quality.

Automatic heat exchanger cleaning



- The heat exchanger surfaces are automatically cleaned by the integrated turbulators, even during heating operation.
- A high level of efficiency is maintained due to clean heat exchangers, resulting in low fuel consumption.
- The combustion and fly ash can simply be removed via the front using the integrated ash tray.
- No side cleaning apertures – therefore less space is required.

4. Flue gas duct

5. Pipe heat exchangers with turbulators and automatic cleaning

6. Double vortex combustion chamber

7. BioControl 3000 controls central control unit

8. Lambda probe Automatic flue and combustion monitoring

9. Suction ventilator speed-controlled and monitored for the highest operational safety

10. Integrated ash tray simple cleaning via pull-out tray

11. Primary and secondary air flaps proportionally controlled separate air input

12. Efficient heat insulation for the lowest radiated heat loss

A range for all requirements...

The HERZ – BioControl 3000: A control for all requirements...

With HERZ BioControl 3000 heating circuits, boiler, buffer and solar can be controlled centrally from the boiler.

The control enables a range of application options. The 2 most common cases are shown below.

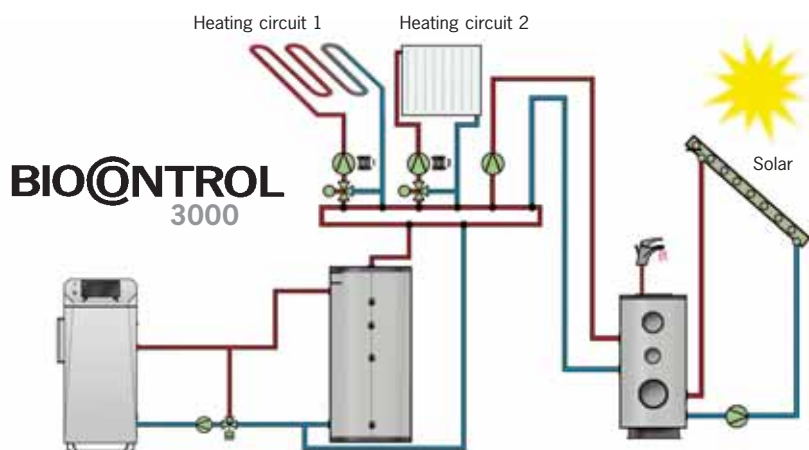

Hot water storage with solar usage and buffer storage:

With this system configuration solar energy is utilised to provide the domestic hot water. When the solar input is insufficient to meet the hot water demand, additional heat is taken from the buffer tank. Additional heating circuits such as under floor heating and the radiators are supplied with heat from the buffer tank.

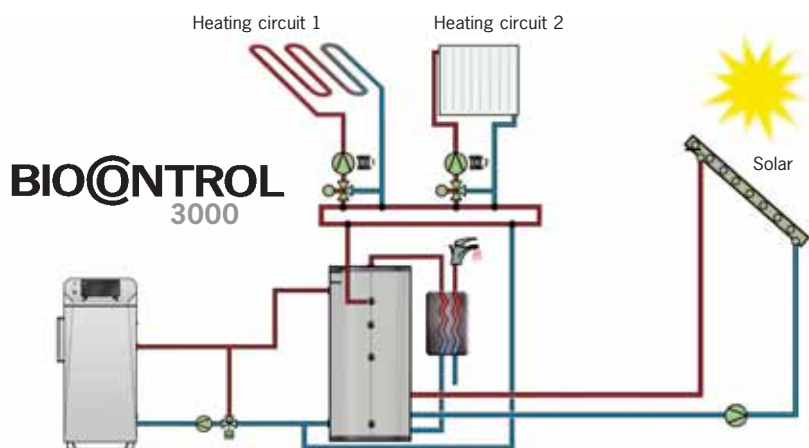

Solar heating support and hygienic hot water preparation:

With this system configuration the solar energy heats the water in the buffer tank directly. Domestic hot water is provided using a heat exchanger. Additional heating circuits such as under floor heating and the radiators are supplied with heat from the buffer tank.



HERZ buffer tank

The installation of a buffer tank considerably increases the efficiency of the heating system, especially during periods of partial load. The variable heat loads from the different heating circuits (e.g. radiators and under floor heating) can be met readily from the buffer.

A buffer tank is sized to store the energy of an the boiler's maximum heat output.

HERZ recommends the following buffer tank sizes for the wood burning boiler:

firestar 15-20: minimum 1500 litres, firestar 30/40: minimum 2000 litres
(Please note the relevant state regulations for buffer storage sizes in order to receive financial support!)

HERZ service water storage

HERZ offers the optimum solution for service water storage with or without solar register - according to the requirements of the customer.

Measurements & technical data...

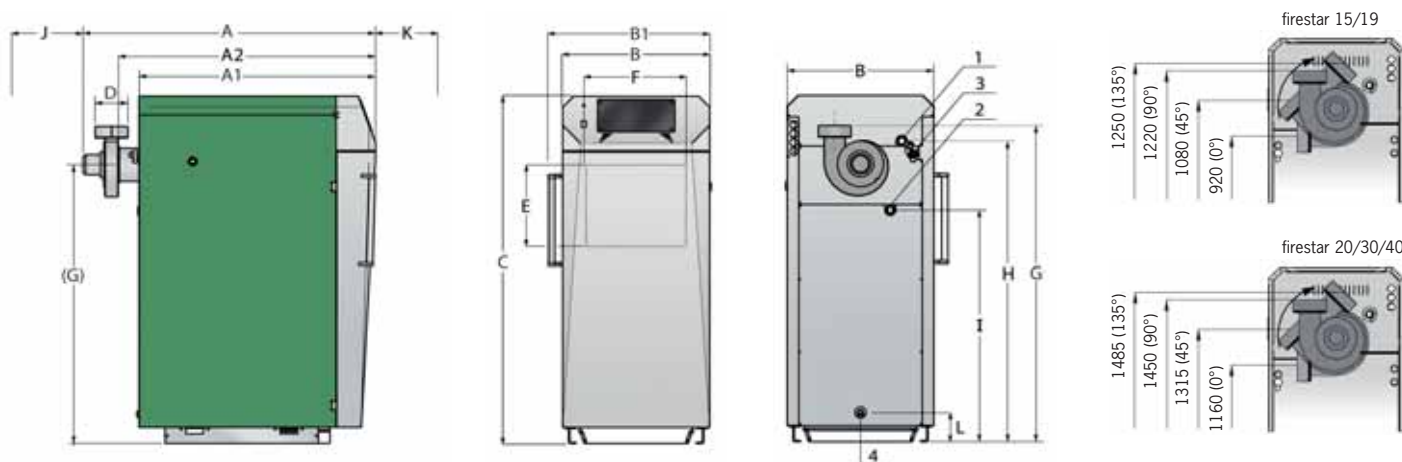

firestar	15	19	20	30	40
Output range (kW)	10,2 - 16,4	10,2 - 20,5	14,3 - 21,5	14,3 - 28,5	19,1 - 40,1
Filling shaft contents (litres)	90	90	170	170	170
Abmessungen (mm)					
A length - total	1370	1370	1370	1370	1370
A1 length - casing	1080	1080	1080	1080	1080
A2 length up to the end of the flue pipe	1210	1210	1210	1210	1210
B width	620	620	670	670	670
B1 width – with door handle	685	685	735	735	735
C height	1365	1365	1590	1590	1590
D flue pipe – diameter	150	150	150	150	150
E filling shaft doors – height	260	260	305	305	305
F filling shaft doors – width	400	400	460	460	460
G flue pipe – upper edge	1220	1220	1450	1450	1450
(G) flue pipe - centre	1040	1040	1275	1275	1275
H flow connection height	1145	1145	1380	1380	1380
I return connection height	840	840	1065	1065	1065
J minimum clearance rear	500	500	500	500	500
K minimum clearance front	520	520	570	570	570
L filling / emptying connection height	135	135	135	135	135
Technical data					
Boiler weight	kg	515	515	612	612
Level of efficiency η_F	%	>93	>93	>93	>91
flue draft requirements (min./max.)	mbar	0,05/0,20	0,05/0,20	0,05/0,20	0,05/0,20
maximum water pressure	bar	3,0	3,0	3,0	3,0
maximum water temperature	°C	90	90	90	90
water capacity	l	77	77	106	106
Electrical connection (V,Hz,A) / connection output (kW)		230,50,10/0,01	230,50,10/0,01	230,50,10/0,01	230,50,10/0,01
Emission values at full load					
Flue gas temperature	°C	<140	<160	<140	<160
Flue gas mass flow rate	kg/s	0,0087	0,0116	0,0116	0,0151
CO ₂ content	Vol. %	15,4	15,6	15,5	15,6
Emission values at partial load					
Flue gas temperature	°C	<100	<100	<100	<100
Flue gas mass flow rate	kg/s	0,00395	0,00791	0,00791	0,00791
CO ₂ content	Vol. %	14,7	14,7	15,0	14,5

Door hinge can be moved from RIGHT to LEFT as standard

- 1...Flow 1" internal thread
- 2...Return 1" internal thread
- 3...Safety heat exchanger 1/2" external thread
- 4...Filling / emptying connection 1/2" internal thread

The complete system using HERZ...

A sensible combination for the future:
Wood gasification boiler with solar heating
The HERZ Sunstar flat collector is hot!

- To increase convenience and reduce costs, solar collectors can be connected either directly to the domestic hot water cylinder, providing 'free' top up hot water or supplied into the buffer tank to supplement the hot water to the space heating system.



Quality with HERZ:

- Pellet boilers
- Wood chip boilers
- Wood gasification boiler
- Heat pumps
- Buffer / Hot water tanks
- Solar technology

Your partner:



HERZ Armaturen Ges.m.b.H.
Geschäftsbereich Herz Feuerungstechnik
A-8272 Sebersdorf 138
Tel. +43/(0)3333 / 2411 - 0
Fax +43/(0)3333 / 2411 - 73
office@herz-feuerung.com
www.herz-feuerung.com



HERZ-Feuerungstechnik
exceeds the strictest
emission regulations.